



Ashgrove Climate Action Group

Solar Hot Water Drive—
Community Bulk Buy Initiative

In the market for a new hot water system?

ACAG has initiated a solar hot water drive where we are encouraging residents from Ashgrove and all over Brisbane to consider installing a solar hot water system. By doing this as a group we hope to negotiate a reasonable discount from one of the local suppliers.

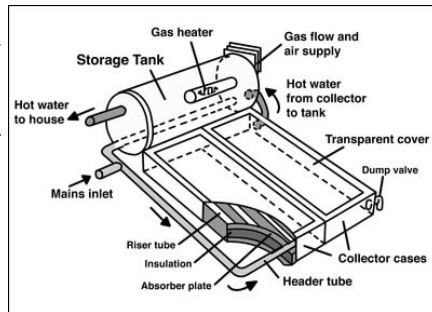

Replacing an existing electric system with solar will save you money on your power bill and, depending on your situation, the overall financial payback period could be less than 5 years, especially if the cost of energy rises.

If you are concerned about lowering your carbon emissions, installing a Solar Hot Water System can cut your emissions by 30% of your normal household energy use.

See over for more information...



Ashgrove Climate Action Group

Solar Hot Water Drive—
Community Bulk Buy Initiative

In the market for a new hot water system?

ACAG has initiated a solar hot water drive where we are encouraging residents from Ashgrove and all over Brisbane to consider installing a solar hot water system. By doing this as a group we hope to negotiate a reasonable discount from one of the local suppliers.

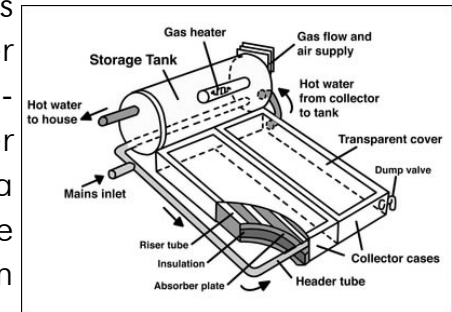

Replacing an existing electric system with solar will save you money on your power bill and, depending on your situation, the overall financial payback period could be less than 5 years, especially if the cost of energy rises.

If you are concerned about lowering your carbon emissions, installing a Solar Hot Water System can cut your emissions by 30% of your normal household energy use.

See over for more information...

Ashgrove Climate Action Group – Solar Hot Water Bulk Buy

Our plan is to negotiate a "sliding scale" of discounts, with a greater discount available as the number of participants rises. This would give the participants an incentive to bring friends onto the scheme to bring the price down further. We will be negotiating with representatives from most well known brands to selected a supplier.

The criteria that we will be using to select the supplier are (in no particular order):

- ⇒ Price
- ⇒ Proven lifespan of installed product
- ⇒ Availability of a percentage discount across all models
- ⇒ Australian owned/manufactured
- ⇒ Warranty
- ⇒ Availability of payment plans

All the suppliers offer a broad range of models, including "split" systems (where the tank is kept on the ground), frost-resistant, boosters, etc. Retrofitting an existing electric or gas hot water tank may be possible but has not been recommended. Heat pump systems may also be available for those who live in shaded areas. We will be investigating Government rebates at all levels which are available for Solar HWS installation.

If you would like more information on this scheme or would like to register your interest, please contact us on **3366-6246** or email: emma@gwhiz.com.au

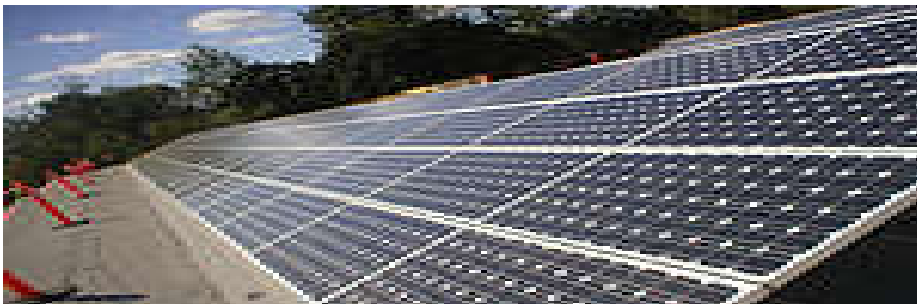

Ashgrove Climate Action Group is a non-profit, local initiative to allow participants to become fully informed on the Climate Change issue, and to provide support and resources to take action at a personal and community level.

For more information about us please go to the **Save Our Waterways Now** website: <http://www.saveourwaterwaysnow.com.au>, and click on the **ACAG** icon.

Ashgrove Climate Action Group—Solar Hot Water Bulk Buy

Our plan is to negotiate a "sliding scale" of discounts, with a greater discount available as the number of participants rises. This would give the participants an incentive to bring friends onto the scheme to bring the price down further. We will be negotiating with representatives from most well known brands to selected a supplier.

The criteria that we will be using to select the supplier are (in no particular order):

- ⇒ Price
- ⇒ Proven lifespan of installed product
- ⇒ Availability of a percentage discount across all models
- ⇒ Australian owned/manufactured
- ⇒ Warranty
- ⇒ Availability of payment plans

All the suppliers offer a broad range of models, including "split" systems (where the tank is kept on the ground), frost-resistant, boosters, etc. Retrofitting an existing electric or gas hot water tank may be possible but has not been recommended. Heat pump systems may also be available for those who live in shaded areas. We will be investigating Government rebates at all levels which are available for Solar HWS installation.

If you would like more information on this scheme or would like to register your interest, please contact us on **3366-6246** or email: emma@gwhiz.com.au

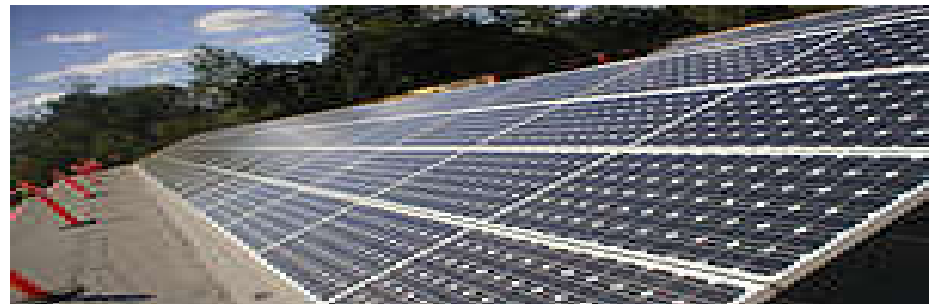

Ashgrove Climate Action Group is a non-profit, local initiative to allow participants to become fully informed on the Climate Change issue, and to provide support and resources to take action at a personal and community level.

For more information about us please go to the **Save Our Waterways Now** website: <http://www.saveourwaterwaysnow.com.au>, and click on the **ACAG** icon.